

Pharmacy Product Catalogue

2023

ly Pharmacy



FlowSell™

flowsell.com.au

Shelves

All of the following shelves will fit wall units, double sided gondolas and wall stripping.

Flat Shelf

Width	600
	915
Depth	305
	405
	505

- white powder coated
- low cost
- easy to clean
- improve shelf management with
 - Mounting Strips
 - Mounting Risers
 - Shelf Dividers

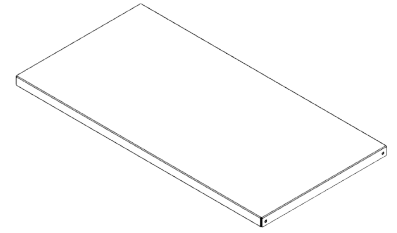

TrayShelf

Width	600
	915
Depth	305
	405
	505

- slotted for FastFit Dividers
- recess for a clear shelf front
- support pins for cabinets
- superior shelf management
- low cost gravity feed

* patent & design registration

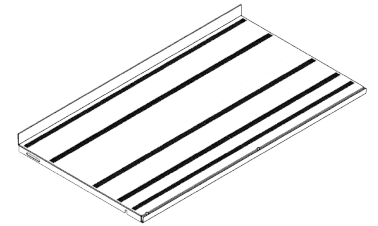

PullOut TrayShelf

Width	600
	915
Depth	305
	405
	505

- quality drawer runners
- push-pad opening
- self-locking
- superior stock rotation
- improves workflow
- slotted for FastFit Dividers

* patent & design registration

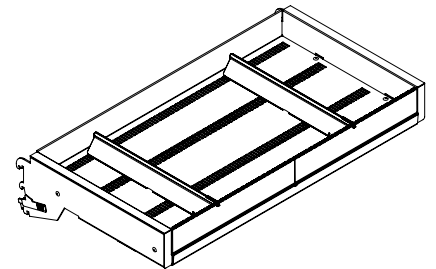

PullOut Slip Shelf

Width	600
	915
Depth	305
	405
	505

- open base design
- infection & hygiene control
- easy to clean
- quality drawer runners
- push-pad opening
- self-locking
- superior stock rotation
- slotted for FastFit Dividers

* patent & design registration

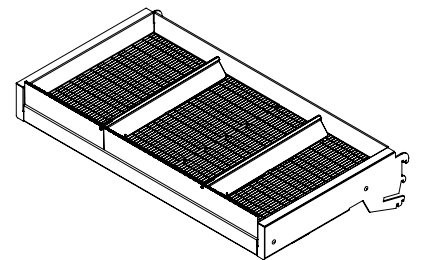

Wire Shelf

Width	600
	915
Depth	305
	405
	455
	505

- stores bulk & heavy stock
- easy to clean
- chrome finish
- 80kg load rating
- heavy duty brackets

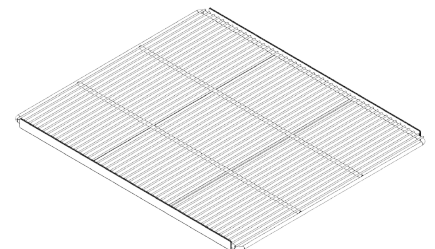

Smart Shelf

Width	598
Depth	305

- low cost gravity feed
- clear polycarbonate shelf
- permanent clear shelf front
- slotted for FastFit Dividers
- fits brackets or support pins

* design registration

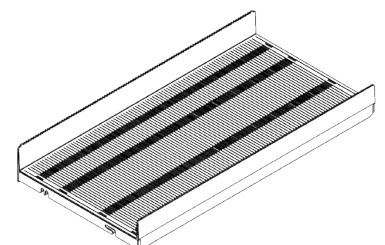

Wall Unit

Highly functional wall units and double gondolas that can be easily modified to suit your workspace.

Choose from the different shelf options that suit your shelving needs.

- heavy duty gondola
- white powder coated
- double slotted posts
- adjustable feet
- easy to assemble

Height	1350		
	1550		
	2260		
Depth	Gondola	Shelf	
	407	305	
	507	405	
Width	No. of Bays	600	915
	1	645	960
	2	1246	1876
	3	1850	2794
	4	2450	3710

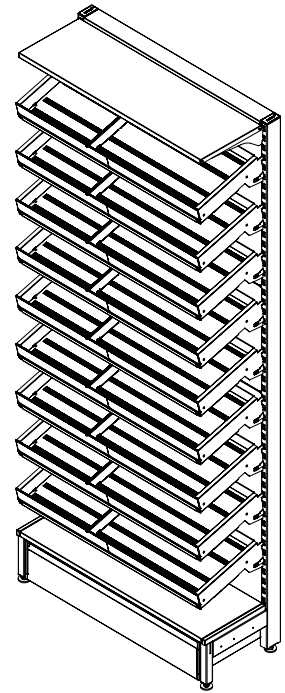

Gondola Drawer

Width	590
	905
Depth	305
	405

Used to store excess stock at the base of the gondola. Fits wall units and double sided gondolas.

- quality drawer runners
- can be partitioned with FastFit Dividers

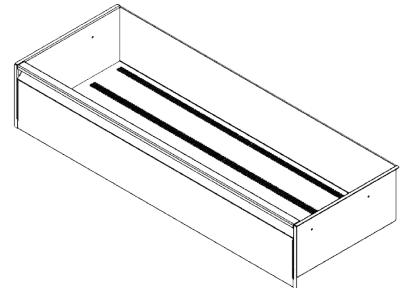

Double Sided Gondola

Height	1350		
	1550		
	2260		
Depth	Gondola	Shelf	
	740	305	
	940	405	
Width	No. of Bays	600	915
	1	645	960
	2	1246	1876
	3	1850	2794
	4	2450	3710

Ideal for island gondolas for the front of shop.

Choose from the different shelf options that suit your shelving needs.

- heavy duty gondola
- white powder coated
- double slotted posts
- adjustable feet
- easy to assemble

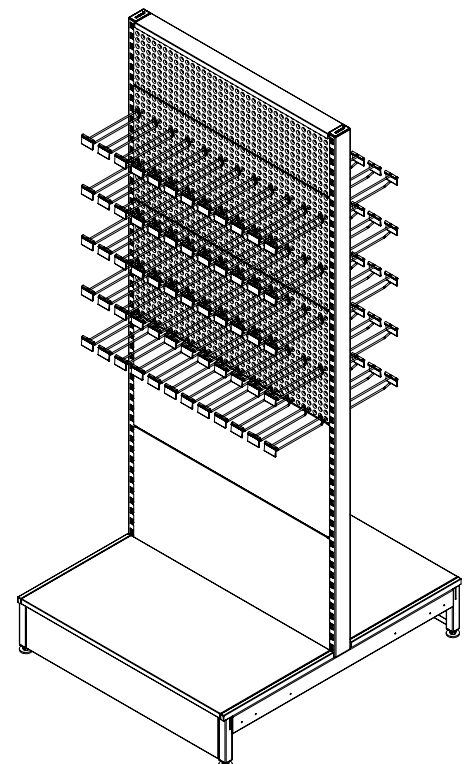

MediTray

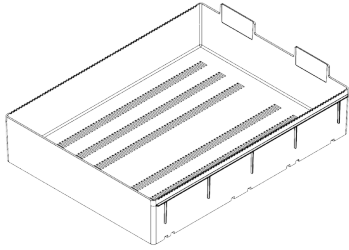

Dual MediTray

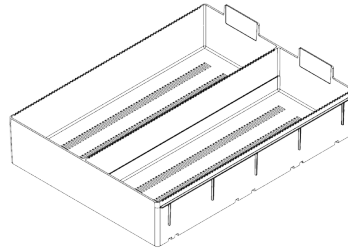

Height	125*
	250**
Depth	450
	600
	915
Width	355

These tray inserts are interchangeable in metal drawer frames with drawer runners, to create drawers of three lengths. MediTrays for conventional storage and Dual MediTrays for the ordered storage of medications.

- drawer inserts for the underbench drawers and the drawer tower
- slotted base for drawer dividers
- excellent management of medications
- strong polycarbonate construction

* for medications

** for higher packs, scripts on file and blister packs.

UnderBench Dispensa Drawers

Width	Bays	
	1 Bay	444
	2 Bays	856
Depth	Drawer Type	
	450	525
	600	675
Height	No. of Drawers	
	4 drawers	586
	5 drawers	716
	6 drawers	846

High capacity, underbench dispensing drawers for easy access to medications.

- fits any underbench space
- soft close drawer runners
- single and double bays

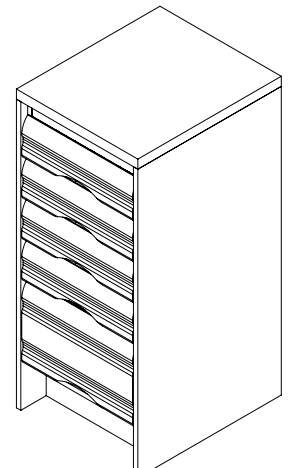

Dispensa Drawer Tower

Height	2020	
Width	No. of Bays	
	1 Bay	445
	2 Bays	890
	3 Bays	1335
Depth	Drawer Type	
	600 Drawer	780
	915 Drawer	1082

The best option to store a large number of medications on a small footprint in drawers.

- powder coated metal drawer tray
- soft close drawer runners
- modern moulded drawer fronts
- high storage capacity with minimal footprint
- step for top drawers

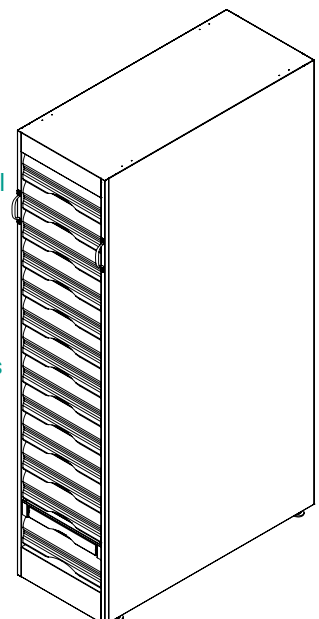

PullOut TrayShelf on Wall Stripping

Length	1800*		
Depth	Wall	Shelf	
	350	305	
	450	405	
Width	550	505	
	No. of Bays	600	915
	1	612	927
	2	1220	1850
	3	1826	2770
4	2435	3696	

* cut to any length

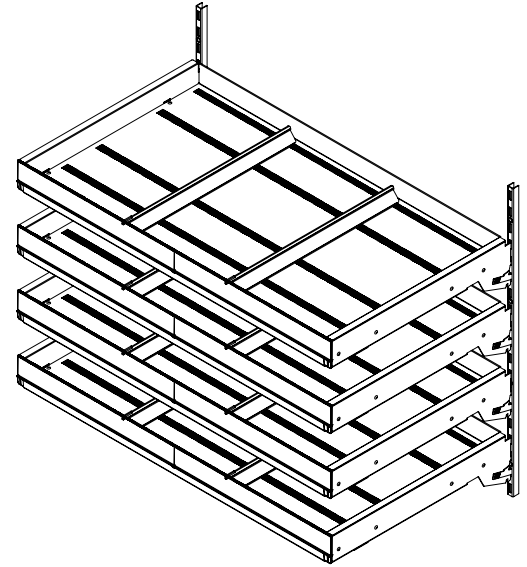

Versatile mounting option for fixing shelves onto walls. All shelf types can be attached to suit your workspace needs.

- heavy duty
- white powder coated
- 41mm pitch brackets
- flexible placement
- single or double slotted
- dust free attachment

A modular cabinet system to customise your own unique workspace and dispensing benches.

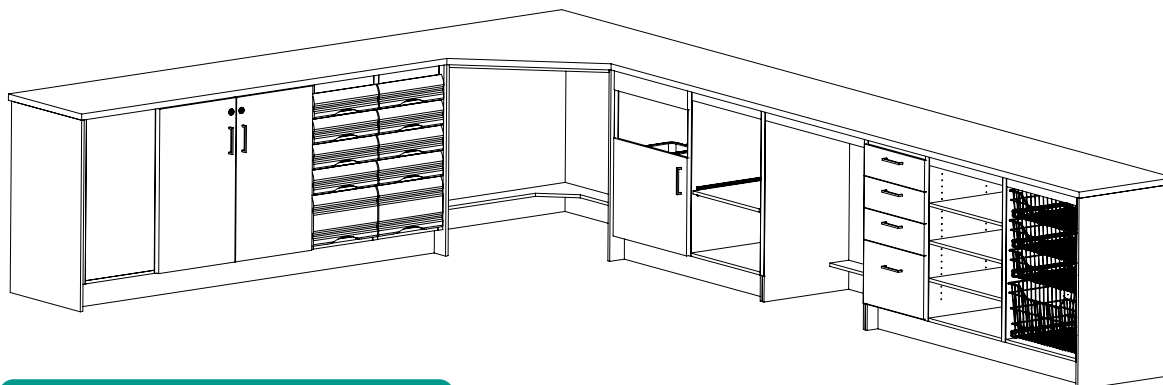

Sitting or Standing Bench

	Sitting	Standing
Height	750	1010
Depth	700	700
Width	948	948

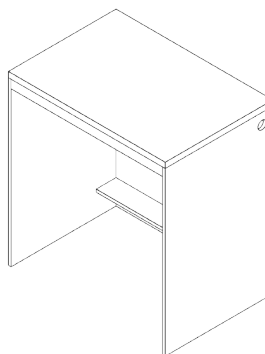

Standing

A melamine cabinet module with a 32mm bench top at one metre high, with an open space to fit an optional pedestal chair.

Sitting

A melamine cabinet module with a 32mm bench top at 750mm high, with an open space for a chair and adequate leg room.

Work Bench

Height	750	1010
Depth	550	700
Width	632	948

This cabinet is made to take adjustable melamine shelves on support pins. It has a base plinth and a 32mm benchtop.

Drawer runners can be added to a melamine shelf to slide out a printer.

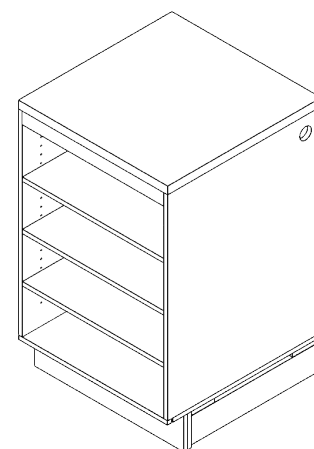

Basket Cabinet

Height	750	1010
Depth	550	700
Width	607	607

A melamine cabinet to fit wire baskets on light or heavy-duty drawer runners with a 32mm bench top and base plinth.

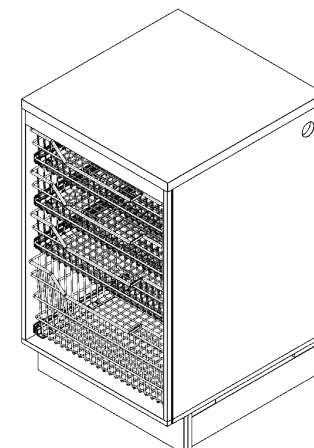

Dispensa Drawer Cabinet

Height	750	1010
Depth	550	700
Width	412	412

A melamine cabinet designed to fit Dual MediTrays for medication storage or an open MediTray for drawer organisation.

- soft close drawer runners
- powder coated metal drawer tray

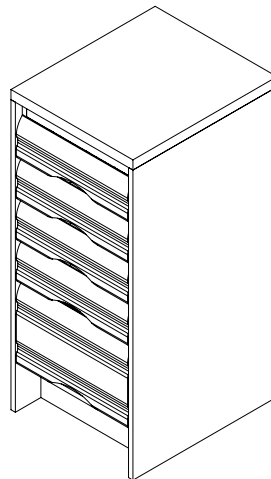

Drawer configuration

750 high Cabinet

Drawer Height	125	250
No. of Drawers	4	0
	2	1
	0	2

1010 high Cabinet

Drawer Height	125	250
No. of Drawers	6	0
	4	1
	2	2
	0	3

Melamine Drawer Cabinet

Height	750	1010
Depth	550	700
Width	412	412

A melamine cabinet with conventional melamine drawers for general storage.

- soft close drawer runners

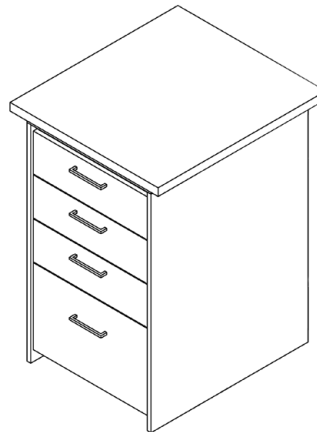

Drawer configuration

750 high Cabinet

Drawer Height	205	320
No. of Drawers	1	1

1010 high Cabinet

Drawer Height	160	320
No. of Drawers	3	1

Waste Bin Cabinet

Height	750	1010
Depth	550	700
Width	412	412

Designed with a hinge door to conceal a rubbish bin with one melamine drawer above, or fitted with a PullOut Rubbish Bin.

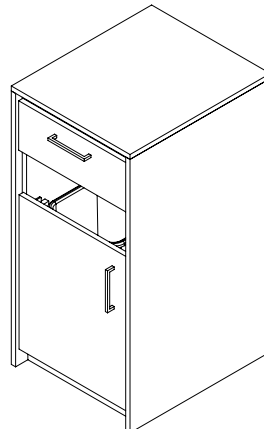

PullOut Waste Bin Cabinet

Height	1010
Depth	700
Width	400



Flowsell® make custom cabinets for S3 products and medications in the dispensary

MediWall

Height	2300		
Depth	524		
Width	No. of Bays	600	915
	1	697	1012
	2	1330	1958
	3	1963	2905

A combination of melamine cabinets to display S3 medications.

- excellent presentation
- attractive display
- drawers for scripts-on-file

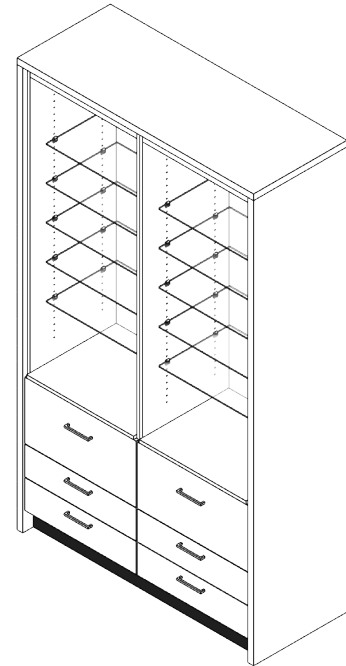

Rear Load

Height	2300		
Depth	Cabinet	Shelf	
	520	405	
	580	505	
Width	No. of Bays	600	915
	1	730	1045
	2	1395	2025
	3	2060	3005
	4	2725	3985
	5	3390	4965
	6	4055	5945
	7	4720	6925

Cabinets positioned parallel to the dispensary bench where non-clinical staff stock fast movers from behind, while technical staff dispense from the front.

- superior stock rotation
- locates more fast movers at the dispensary bench
- ideal for large dispensaries
- separates technical from non-technical staff

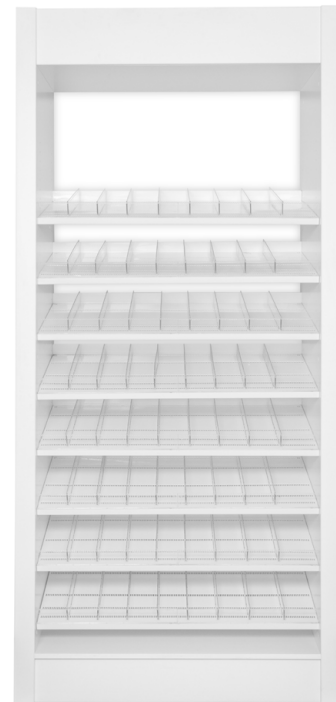

E-Dispensa Cabinet

The cabinet shell fitted with the Flowsell® clear polycarbonate SmartShelf, typically arranged in a finger formation to create a highly ordered and functional dispensary.

Height	2300
Depth	365
Width	633

Cabinet

- excellent stock rotation
- easy and quick installation
- space efficient
- low cost

SmartShelf

- tough polycarbonate moulding
- fixed clear Shelf Front
- slotted base for Fast Fit Dividers
- fits support pins, drawer runners or brackets
- fits pullout drawer runners
- dockable for narrow bays
- high medication visibility

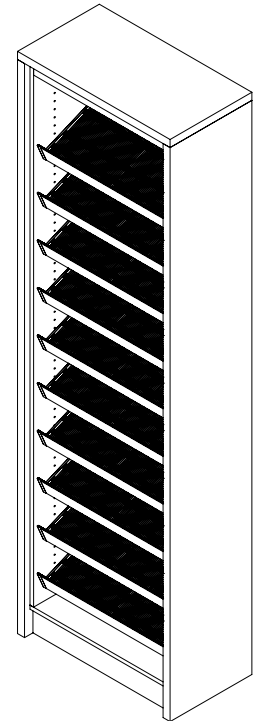

Wire Racks

Chrome Wire Rack

Flowsell® have chrome wire racks for back of pharmacy storage or retail display.

Height	
1800	2185
Depth	Width
355mm	603mm
355mm	1213mm
457mm	603mm
457mm	908mm
457mm	1213mm
457mm	1518mm
457mm	1822mm
610mm	908mm
610mm	1213mm
610mm	1518mm
610mm	1822mm

All wire racks are manufactured to the highest quality and come with a five-year guarantee. Racks have NSF and salt test certification.

- easy to assemble
- 250kgs load per shelf (spread evenly)
- quality chrome or epoxy finish
- corrosion resistant

